



education

Department:
Education
REPUBLIC OF SOUTH AFRICA

**NATIONAL
SENIOR CERTIFICATE**

GRADE 10

PHYSICAL SCIENCE P1

NOVEMBER 2006

This memorandum consists of 12 pages.

Learning Outcomes and Assessment Standards Leeruitkomst en Assesseringstandaarde		
LO 1	LO 2	LO 3
<p>AS 10.1.1: Plan and conduct a scientific investigation to collect data systematically with regard to accuracy, reliability and the need to control one variable. <i>Beplan en voer 'n wetenskaplike ondersoek uit om data sistematies met akkuraatheid, betroubaarheid en die kontrole van een veranderlike, te versamel.</i></p> <p>AS 10.1.2: Seek patterns and trends in the information collected and link it to existing scientific knowledge to help draw conclusions. <i>Soek patrone en tendense in die versamelde inligting en verbind dit met bestaande wetenskaplike kennis om gevolgtrekkings te maak.</i></p> <p>AS 10.1.3: Apply given steps in a problem-solving strategy to solve standard exercises. <i>Pas gegewe stappe in 'n probleemoplossingstrategie toe om standaard oefeninge op te los.</i></p>	<p>AS 10.2.1: Recall and state basic prescribed scientific knowledge. <i>Onthou en noem basiese voorgeskrewe wetenskaplike kennis.</i></p> <p>AS 10.2.2: Express and explain prescribed scientific theories and models by indicating some of the relationships of different facts and concepts with each other. <i>Verduidelik en druk voorgeskrewe wetenskaplike teorieë en modelle uit deur van die verwantskappe tussen verskillende feite en konsepte aan te dui.</i></p> <p>AS 10.2.3: Apply scientific knowledge in familiar, simple contexts. <i>Pas wetenskaplike kennis in bekende eenvoudige kontekste toe.</i></p>	<p>AS 10.3.2: Describe the interrelationship and impact of science and technology on socio-economic and human development. <i>Beskryf die interverwantskap en impak van wetenskap en tegnologie op sosio-ekonomiese en menslike ontwikkeling.</i></p>

SECTION A / AFDELING A**QUESTION 1 / VRAAG 1**

1.1	Displacement / <i>Verplasing</i> ✓	[10.2.1]	(1)
1.2	Wavelength / <i>Golflengte</i> ✓	[10.2.1]	(1)
1.3	Refractive index / <i>Brekingsindeks</i> ✓	[10.2.1]	(1)
1.4	Insulators or non-conductors / <i>Nie-geleiers</i> ✓	[10.2.1]	(1)
1.5	Electric / <i>Elektriese</i> ✓	[10.2.1]	(1)
			[5]

QUESTION 2 / VRAAG 2

2.1	I ✓	[10.2.1]	(1)
2.2	F ✓	[10.2.1]	(1)

- | | | | | |
|-----|-----|--|----------|------------|
| 2.3 | H ✓ | | [10.2.1] | (1) |
| 2.4 | J ✓ | | [10.2.1] | (1) |
| 2.5 | G ✓ | | [10.2.1] | (1) |
| | | | | [5] |

QUESTION 3 / VRAAG 3

- | | | | | |
|-----|---------------------|---------------------------------------------------------------------------------------------------------------------------------------------------------------------------------------|----------|-------------|
| 3.1 | True ✓✓
Waar | | [10.2.3] | (2) |
| 3.2 | False. ✓✓
Onwaar | It's gravitational potential energy decreases.
<i>Sy gravitasie-potensiële energie neem af.</i> | [10.2.3] | (2) |
| 3.3 | False. ✓✓
Onwaar | The amplitude is the vertical distance from the position of rest to the crest or trough.
<i>Die amplitude is die vertikale afstand tussen die Rusposisie en die kruin of buik.</i> | [10.2.1] | (2) |
| 3.4 | False ✓✓
Onwaar | Endoscopes make use of total internal reflection of light.
<i>Endoskope maak gebruik van totale interne weerkaatsing van lig.</i> | [10.3.2] | (2) |
| 3.5 | True ✓✓
Waar | | [10.2.1] | (2) |
| | | | | [10] |

QUESTION 4 / VRAAG 4

- | | | | | |
|-----|-------|--|----------|-------------|
| 4.1 | B ✓✓✓ | | [10.1.2] | (3) |
| 4.2 | C ✓✓✓ | | [10.2.3] | (3) |
| 4.3 | D ✓✓✓ | | [10.2.3] | (3) |
| 4.4 | A ✓✓✓ | | [10.2.3] | (3) |
| 4.5 | D ✓✓✓ | | [10.2.3] | (3) |
| | | | | [15] |

Total Section A / Totaal Afdeling A = [35]

QUESTION 5 / VRAAG 5

5.1

Graph of stopping distance vs speed / Grafiek van stilhou-afstand vs spoed

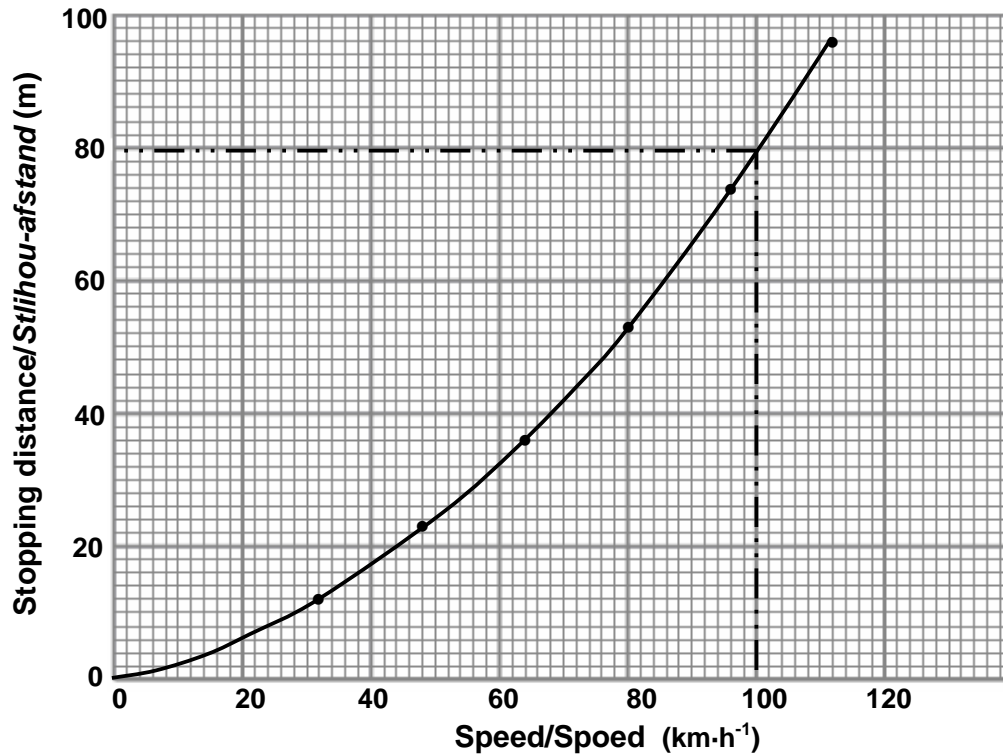

Checklist / Kontrolelys	1	0
Relevant heading and correct labels with units on both axes. <i>Geskikte opskrif en korrekte namemet eenhede opbeide asse.</i>		
Correct scale on x-axis <i>Korrekte skaal op x-as</i>		
Correct scale on y-axis <i>Korrekte skaal op y-as</i>		
All points correctly plotted. <i>Alle punte korrek geplot.</i>		
Curve drawn correctly. <i>Kurwe korrek geteken.</i>		
Total / Totaal 5		

- 5.2 Stopping distance increases more and more rapidly as the car's speed increases OR stopping distance \propto (speed)² [10.1.2] (5)
Stilhou afstand neem meer en meer toe soos die motor se spoed toeneem OF Stilhou afstand \propto (spoed)² ✓✓
- 5.3 78 – 82 km·h⁻¹ ✓ Indicated on graph / *Aangedui op grafiek*
 Mark positively from graph/ *Merk positief vanaf die grafiek* ✓ [10.1.2] (2)

- 5.4 Any three relevant precautions which will increase the reaction time. ✓✓✓
Enige drie relevante voorsorgmaatreëls wat reaksietyd verhoog.

Examples:

Do not drink and drive.

Ensure the car's brakes are in good condition.

Do not use a cell phone while driving.

Keep a safe following distance.

Keep to the speed limit.

Do not overload your car - as mass increases stopping distance increases.

Tyres should have enough tread.

Voorbeelde:

Moenie drink en bestuur nie.

Maak seker dat die motor se remme in 'n goeie toestand is.

Moenie 'n selfoon gebruik wanneer jy bestuur nie.

Hou 'n veilige volgafstand.

Hou binne die spoedgrens.

Moenie jou motor oorlaai nie – soos massa toeneem neem die stilhou afstand toe

Bande moet genoeg loopvlak hê

[10.3.2]

(3)

[12]

QUESTION 6 / VRAAG 6

6.1 $v_f = v_i + a\Delta t \checkmark = 0 \checkmark + (1,6)(10) \checkmark = 16 \text{ m}\cdot\text{s}^{-1} \checkmark$

[10.1.3] (4)

6.2 $\Delta x = v_i\Delta t + \frac{1}{2}a\Delta t^2 \checkmark = (0)(10) \checkmark + \frac{1}{2}(1,6)(10)^2 \checkmark = 80 \text{ m} \checkmark$

[10.1.3] (4)

6.3 $\Delta x = v_i\Delta t + \frac{1}{2}a\Delta t^2 \checkmark = (16)(20) \checkmark + \frac{1}{2}(0)(20) \checkmark = 320 \text{ m} \checkmark$

[10.1.3] (4)

6.4

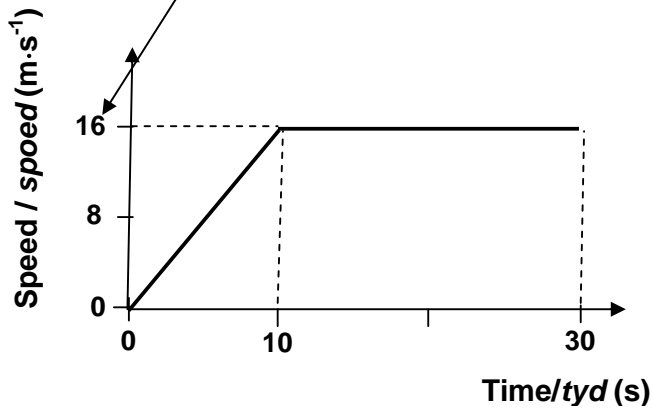

Checklist / Kontrolelys	1	0
Time, 10 s and 30 s indicated on x-axis <i>Tyd, 10 s en 30 s op x-as aangedui</i>		
Speed (16 m·s ⁻¹) indicated on y-axis <i>Spoed (16 m·s⁻¹) op y-as aangedui</i>		
Line correctly drawn for first 10 s <i>Lyn korrek getrek vir eerste 10 s</i>		
Line correctly drawn for last 20 s <i>Lyn korrek getrek vir laaste 20 s</i>		
Total/ Totaal: 4		

[10.1.2] (4)
[16]

QUESTION 7 / VRAAG 7

- 7.1 The sum of the gravitational potential energy and kinetic energy ✓ in an isolated system ✓ is constant.

Die som van die gravitasie-potensiële energie en kinetiese energie ✓
in 'n geïsoleerde sisteem ✓ is constant. [10.2.1] (2)

- 7.2 From conservation principle / *Uit die beginsel van behoud van energie:*
Total mechanical energy at P = total mechanical energy at Q
Totale meganiiese ebergie by P = totale meganiiese energie by Q

$$mgh + \frac{1}{2} m v_i^2 = mgh + \frac{1}{2} m v_f^2 \checkmark$$

$$(55 \times 9,8 \times h) \checkmark + (0 = 0) \checkmark + (\frac{1}{2} \times 55) \checkmark \times (3)^2$$

$$h = \frac{9}{2 \times 9,8} = 0,45 \text{ m} \checkmark \quad [10.1.3] \quad (5)$$

- 7.3.1 The steeper the slope, the greater the value of **h** and the faster one can go down the slope. OR $v^2 \propto h$ ✓✓

Hoe steiler die helling, hoe groter is die waarde van h en hoe vinniger kan hulle die steilte af beweeg. OF $v^2 \propto h$ ✓✓ [10.3.2] (2)

- 7.3.2 Any two dangers / *Enige twee gevare* ✓✓

Examples: / *Voorbeelde:*

- The faster one goes the more difficult it is to stop or slow down .
 - The risk of being run down by passing vehicles.
 - There is a danger of head on collisions when vehicles try to avoid young people.
 - There is an increasing risk of crashing into obstacles and hurting themselves.
 - Such risks also affect families and communities emotionally and economically.
- *Hoe vinniger jy beweeg hoe moeiliker is dit om te stop.*
 - *Die gevaar om deur voertuie om gery te word.*
 - *Daar is 'n gevaar van kop-aan-kopbotsings wanneer voertuie probeer om jong mense te vermy.*
 - *Daar is 'n toenemende gevaar dat hulle teen voorwerpe kan bots en hulleself beseer.*
 - *Families en gemeenskappe kan emosioneel deur hierdie gevare beïnvloed word.* [10.3.2] (2)

- 7.3.3 Loss of energy due to friction between wheels of skateboard and street due to roughness of street surface /Not an isolated system ✓✓

Energie verlies as gevolg van wrywing tussen wiele van skaatsplank en straat as gevolg van die skurfheid van die straatoppervlakte./ Nie 'n geïsoleerde sisteem [10.2.3] (2)

[13]

QUESTION 8 / VRAAG 8

8.1 Superimposed incident and reflected wave have equal – wavelengths, speed and amplitude
Superponeerde invallende en weerkatse golf het dieselfde – golflengte, spoed en amplitude [10.2.1] (3)

8.2

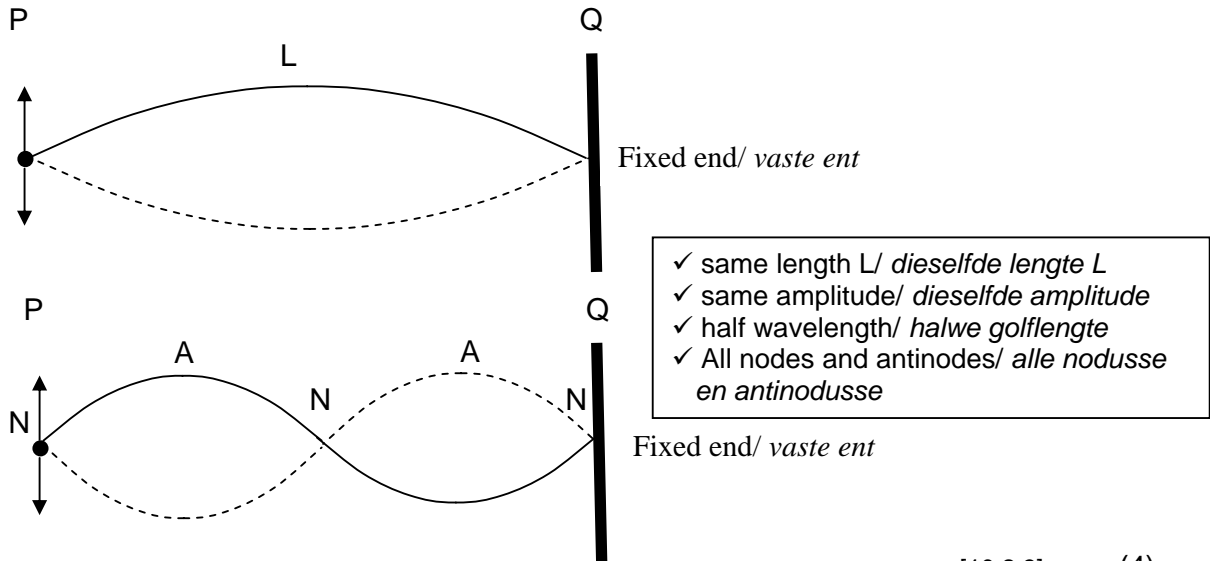

[10.2.3] (4)

8.3 Antinodes – points of maximum disturbance
Antinodus – punt van maksimum versteuring
 Nodes – point of zero disturbance
Nodus – punt van geen versteuring ✓

[10.2.1] (2)

[9]

QUESTION 9 / VRAAG 9

9.1

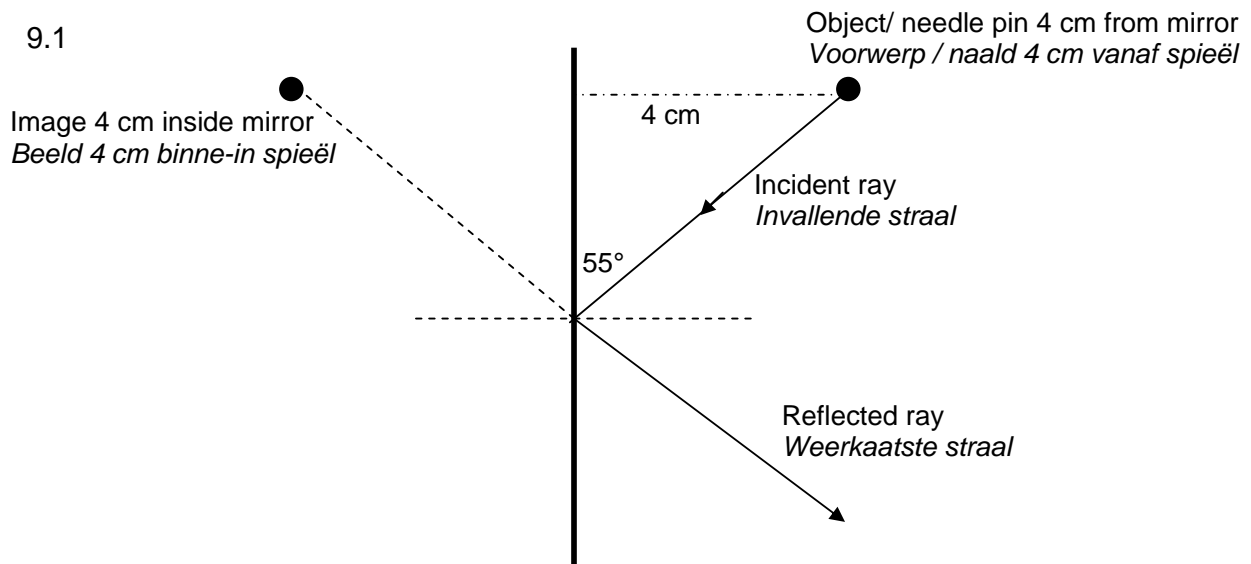

Checklist / Kontrolelys	1	0
Plane mirror 10 cm in length <i>Vlakspieël 10 cm lank</i>		
Office(needle) pin 4 cm \perp to mirror <i>Naald 4 cm \perp spieël</i>		
Incident ray at 55° to mirror (35° to normal) <i>Invallende straal maak hoek van 55° met spieël (35° met normaal)</i>		
Normal at 90° to mirror <i>Normaal 90° met spieël</i>		
Reflected ray at 55° to mirror (35° to normal) <i>Weerkaatste straal maak hoek van 55° met spieël(35° met normaal)</i>		
Image 4 cm inside mirror <i>Beeld 4 cm binne-in spieël</i>		
Total / Totaal 6		

- 9.2 35° ✓✓
Angle of incidence equals angle of reflection ✓✓
Invalshoek gelyk aan weerkaatsingshoek [10.1.1] (6)
- 9.3 Upright / *Regop*
Same size as object / *Dieselfde grootte as die voorwerp*
Laterally inverted / *Sywaarts omgekeerd*
Image distance = object distance / *Beeldafstand = voorwerpafstand*
Virtual / *Virtueel*
[Any three] [10.2.1] (3)
- 9.4 Specular (or regular reflection) occurs when light rays are reflected as a parallel beam or forms a sharp image, ✓ while during diffuse reflection reflected rays are scattered haphazardly. ✓

Spieëlweerkaatsing (of reëlmatige weerkaatsing) vindplaas wanneer ligstrale as 'n parallelle straal weerkaats word of 'n skerp beeld vorm, terwyl weerkaatste strale willekeurig versprei istydens verstrooide weerkaatsing.. [10.2.2] (2)

[15]

QUESTION 10 / VRAAG 10

10.1 Pulse is a single disturbance in a medium
Puls is 'n enkele versteuring in 'n medium ✓✓ [10.2.1] (2)

10.2 Superposition / interference / destructive interference ✓✓
Superposisie / interferensie / destruktiewe interferensie [10.2.1] (2)

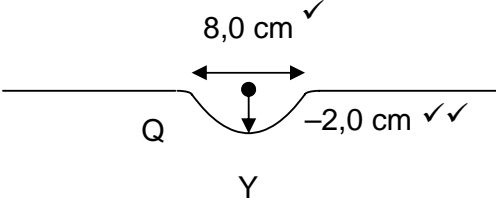
10.3  [10.2.3] (3)

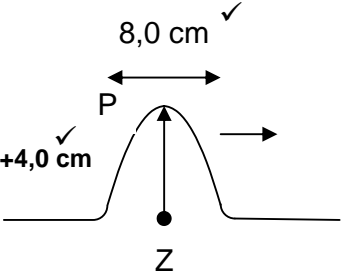
10.4  [10.2.3] (2)

10.5 $\Delta x = v\Delta t$ ✓ $\therefore 0,6$ ✓ = $v(1,5)$ ✓ $\therefore v = 0,4 \text{ m}\cdot\text{s}^{-1}$ ✓ [10.1.3] (4)
[13]

QUESTION 11 / VRAAG 11

11.1 Attract each other due to opposite charges. ✓✓
Trek mekaar aan weens teenoorgestelde ladings. [10.2.3] (2)

11.2 New charge = $\frac{Q_1 + Q_2}{2} = \frac{-x + 2x}{2}$ ✓ = $\frac{x}{2}$ C ✓ [10.1.3] (3)

11.3 Repulsion / *afstotend* ✓ ✓✓
The nature of the charge / Sign of the charge on both spheres is the same
Die aard van die lading / Teken van die lading op beide sferes is dieselfde [10.2.3] (3)

11.4 No. ✓ If the nett charge is zero, they will not move apart. ✓✓
Nee. Indien die netto lading nul is sal hulle nie weg beweeg nie. [10.2.3] (3)
[11]

QUESTION 12 / VRAAG 12

- 12.1.1 Flow of charge (**not** rate of flow of charge) ✓✓
Vloei van lading (nie tempo van ladingvloei nie). [10.2.1] (2)
- 12.1.2 Work done in moving a unit charge from a point of low potential to a point of high potential ✓✓✓..
Arbeid verrig on 'n eenheidslading vanaf 'n posisie van lae potential na 'n punt van hoë potential te beweeg [10.2.1] (3)
- 12.2 Low temperatures cause water droplets to freeze. ✓✓
Lae temperature laat waterdruppels vries. [10.2.3] (2)
- 12.3 $Q = It = 75 \times 1,5 = 112,5 \text{ C}$ ✓ [10.1.3] (4)
- 12.4 $V = \frac{W}{Q}$ ✓
 $\therefore 2\,000\,000 = \frac{W}{112,5}$ ✓
 $\therefore W = 225\,000\,000 \text{ J} = 225 \text{ MJ}$ [10.1.3] (4)
- [15]**

QUESTION 13 / VRAAG 13

13.1

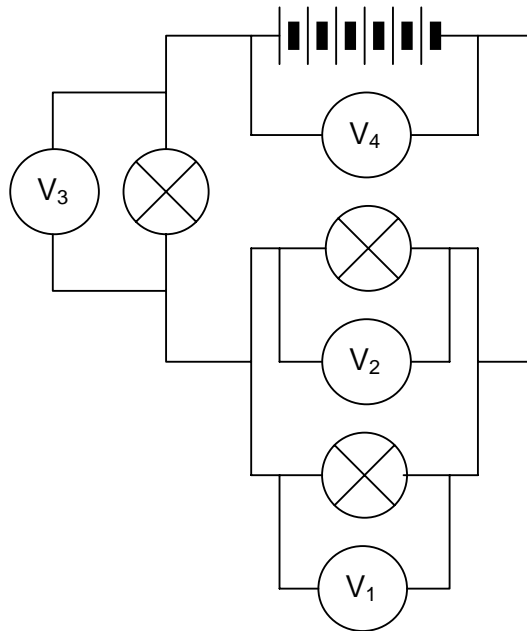

Checklist / Kontrolelys	1	0
6 Cells correctly represented in series. <i>6 Selle korrek in serie voorgestel.</i>		
Bulbs correctly represented in parallel and in series. <i>Gloeilampe in parallel en serie korrek voorgestel.</i>		
Voltmeters connected in parallel across bulbs and cells. <i>Voltmeters parallel oor gloeilampe en selle geskakel.</i>		
Total / Totaal 3		

[10.1.2] (3)

13.2 4 V ✓✓

[10.1.3] (2)

13.3 8 V ✓✓

[10.1.3] (2)

13.4 12 V ✓✓

[10.1.3] (2)

13.5 2 V ✓✓

[10.1.3] (2)

[11]**TOTAL MARKS OF QUESTION PAPER / TOTALE PUNTE VAN VRAESTEL = 150**